

## DEMBS-63 SEMI-AUTO COILER

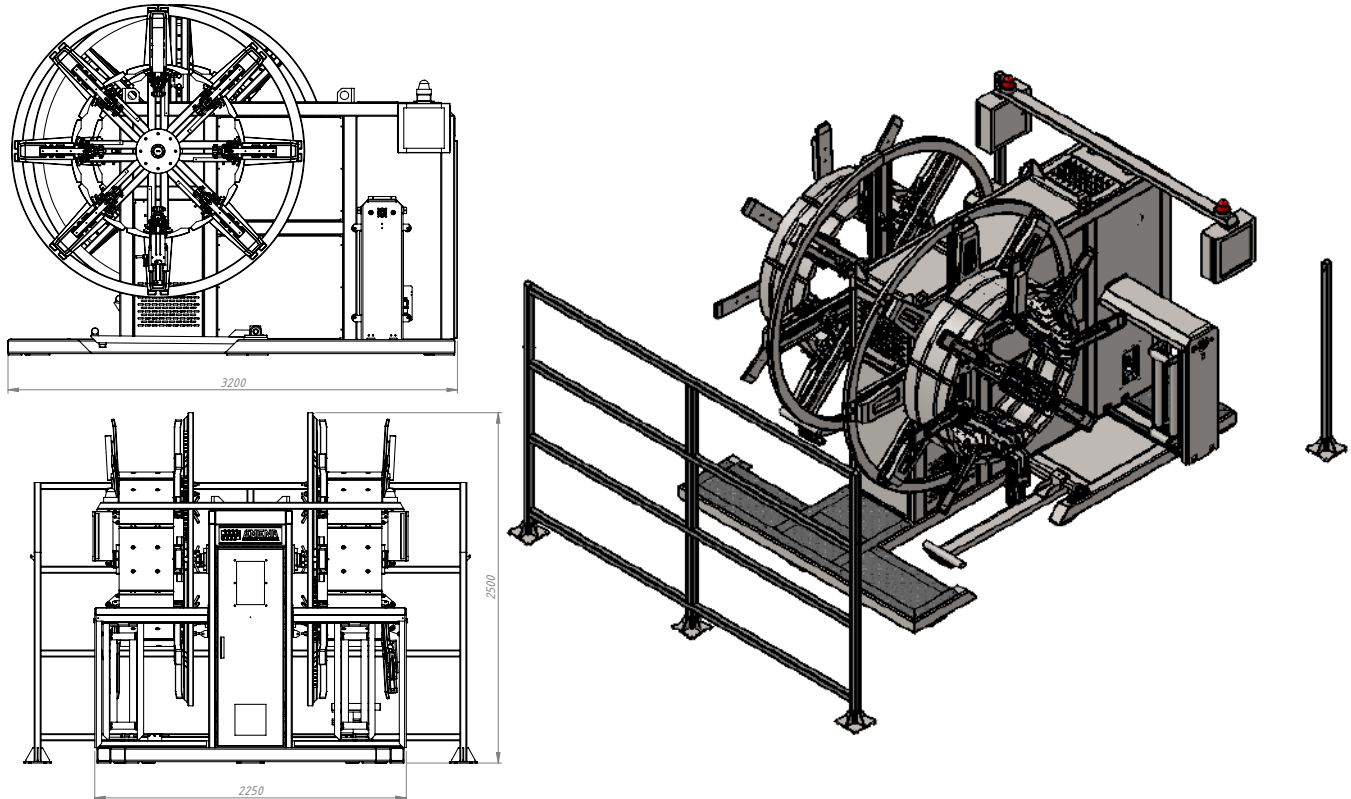

## Features & Specifications

Control :	PLC Control System
Torque Control :	Available
Pipe Range :	20mm – 63mm
Coiling Speed :	30 m/min
Stations :	Double station side by side
Pipe Guide :	Servo Motor Control
Station Arms :	Pneumatic opening and closing
Coil Inside Dia (mm) :	Min 700mm - Max: 1900mm
Max Outside Dia Of Bobbin :	2600mm (min-1400mm)
Coil Width :	Min 50mm – Max 395mm
Coil Flaps :	8
Motor Break :	Included
AC motors will have encoder and air fans	