

## DEMBS-110 SEMI-AUTO COILER

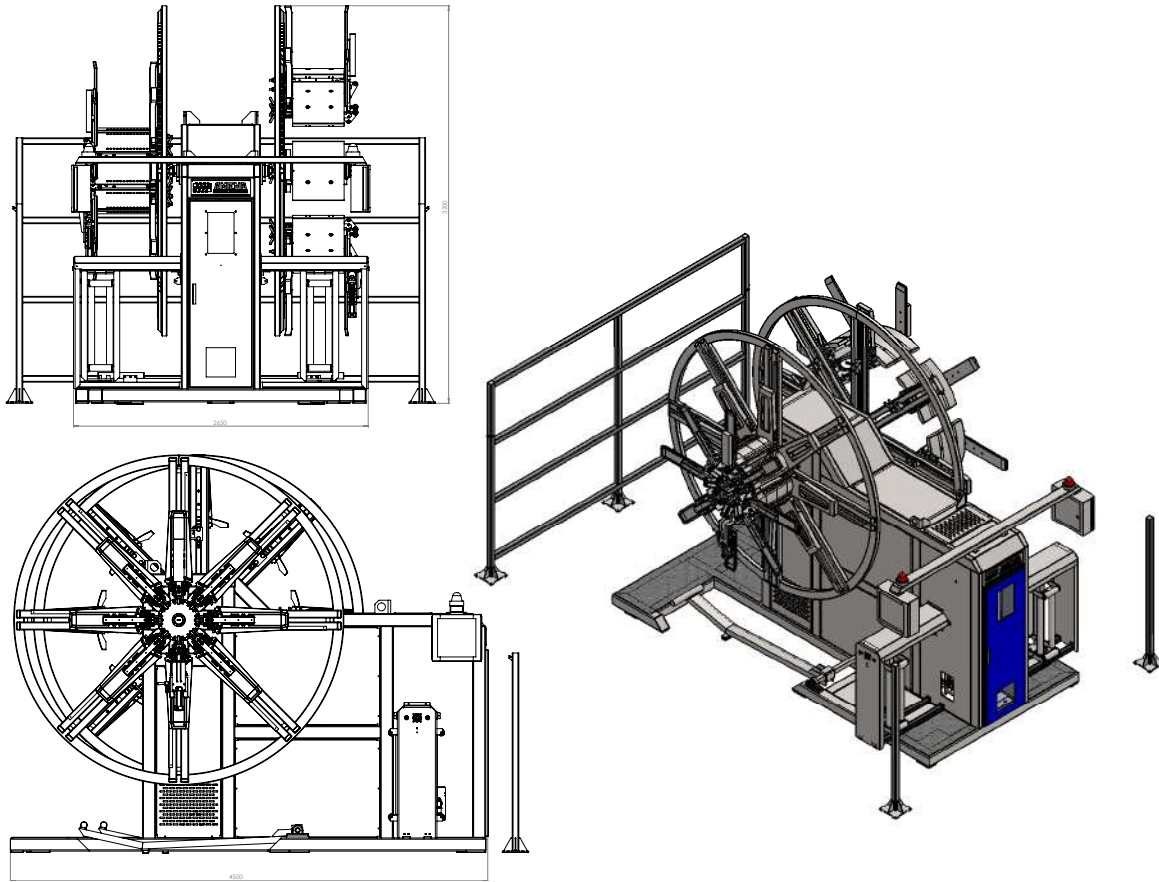

## Features & Specifications

Control :	PLC Control System B&R/SIEMENS
Torque Control :	Available
Pipe Range :	50mm – 110mm
Coiling Speed :	20 m/min
Stations :	Double station side by side
Pipe Guide :	Servo Motor Control
Station Arms :	Pneumatic opening and closing
Pipe Guide Motor :	0.37Kw Lenze-B&R
Pulling Force :	Max 11,935N
Coil Inside Dia (mm) :	Min 800mm - Max: 2100mm
Max Outside Dia Of Bobbin :	3300mm
Coil Width :	Min 150mm – Max 630mm
Station Motors :	2 x 4.0 KW Siemens with Gearbox
Pipe Clamping Unit :	Included
Pipe Tail Clamping Unit :	Included
Color :	RAL 5023