

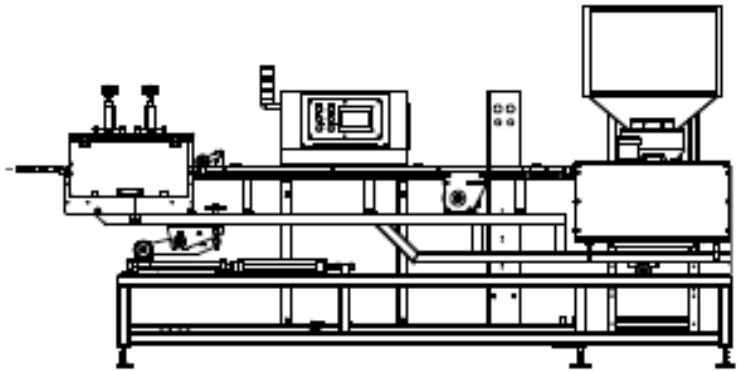

# Round Dripper Insertion Device

*Model DRBI-500*

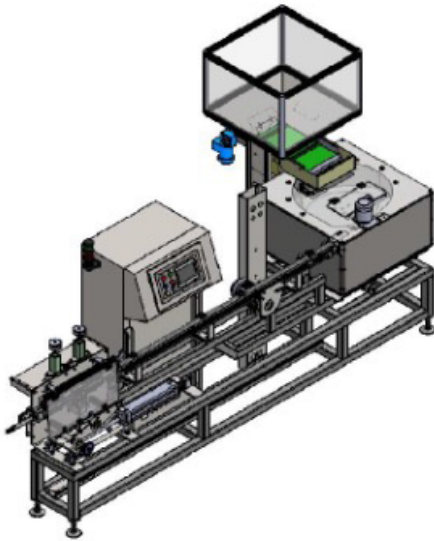

This DRTS high-speed servo driven round dripper inserting machine is built using the same insertion concept as the flat drip machines. The belt driven machines allows us to reach speeds of up to 500 drippers per minute without compromising on the spacing accuracy. This unit is easily integrated to any existing production line and can provide a substantial upgrade to your production.

## Specification

- **Capacity:** 500 dripper/min. 30-70mm length of drippers
- **Diameters:** 12-20mm
- **Minimum Inserting Space:** 20mm
- **Servo Motors:** Kollmorgan/Siemens/Lenze
- **Servo Drivers:** Kollmorgan/Siemens/Lenze
- **Touch Panel:** 7" Kollmorgan
- **Max Line Speed:** 120m/min
- **Tolerances between inserted drippers:** - + %5
- **Bowl Feeder covered by Plexiglass**
- **Continuous feedback dripper conveying system**
- **Very accurate Servo inserting system. It can work continuous and Step-Mode**
- **Special Cooling Tubes located in the crosshead for different dripper types.**
- **Dripper unloading system.**
- **Uniform spacing -Group Spacing -Dripper counting**