

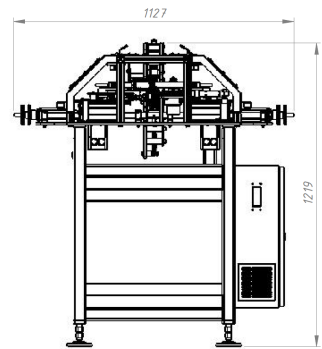

Fast Perforating Device

Model DRSP-500

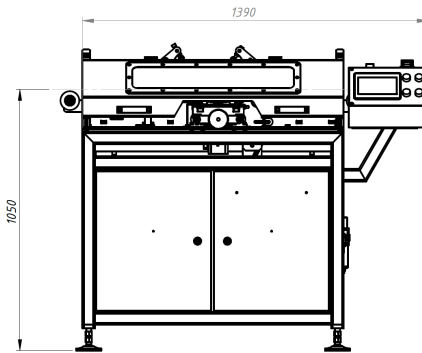
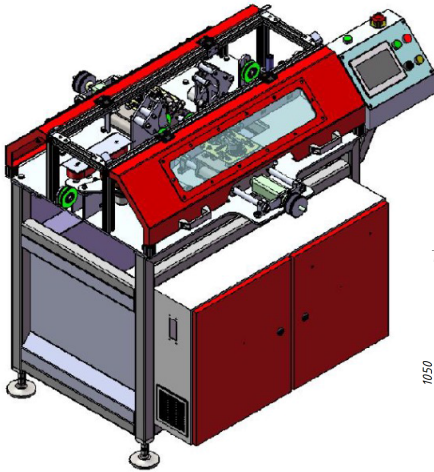

The DRTS Servo Perforator can be easily installed on any existing line without making any changes. It has its own line speed encoder making it an autonomous machine. Spacing measurement including historical report can be retrieved directly from the PLC or via USB port. Hole position can be adjusted via the touchscreen at a resolution of +/- 0.01mm. The depth of the hole can also be adjusted during operation at a resolution of +/- 0.1mm.

Specification

- **Capacity:** 500 dripper/min. 30-70mm length of drippers
- **No of Holes:** 1-4 holes
- **Suitable for Diameter:** 12mm – 20mm
- **Minimum Spacing:** 15 cm
- **Pipe Speed:** up to 120 m/min
- **Center Height:** 1060mm
- **Dimensions:** L:1400mm W:1150mm H:1250mm
- **PLC Panel:** 5.7 inch Touchscreen - KOLLMORGAN
- **Servo driver + PLC:** 2x KOLLMORGAN
- **Servo Motor:** 2x KOLLMORGAN
- **Air Motor:** 70.000 RPM
- **Air Requirement:** 6 BAR
- **Gives Quality Control Trends**
- **High Accuracy of Hole Location**
- **Easy and Quick Drill Depth Adjustment**
- **Easy Integration to any existing production line**
- **No Maintenance Required**
- **Plastic chip vacuum collector:** Optional