

Capstan Haul Off (Flat)

Model DEMTC-300

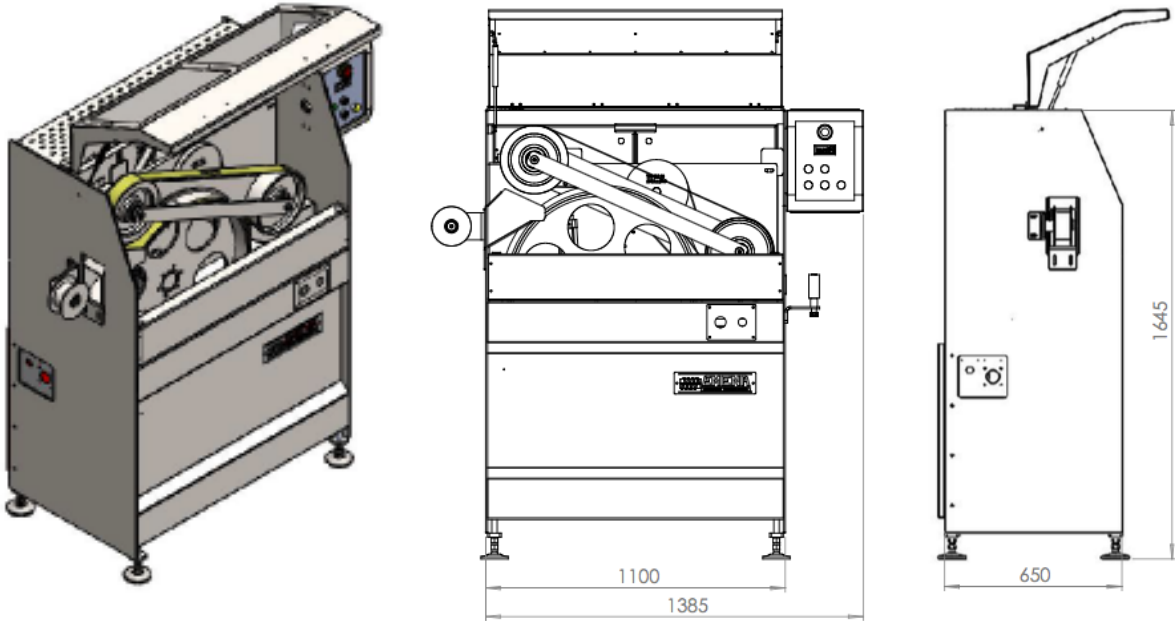

The DRTS Capstan Haul-off can be easily installed on existing lines without making any changes. This high speed Haul-off unit is intended for thin-wall pipe. This unit requires almost no maintenance and has very low wear of parts (no belts). The use of only one motor makes it very energy saving. As no belts are used, there is no friction, making the operating speed very stable.

Specification

- **Pulling Force:** 200 N
- **Diameter Range:** 16 - 32mm
- **Pulling Speed:** 300m/min (Max)
- **No of Arms:** 1 Main Wheel + ¼ Circular Belt
- **Arms Driver:** Servo Motor + Gear Box
- **Encoder Output:** Encoder output from driver or physically connected encoder from shaft
- **Motor:** Siemens/Kollmorgan/Lenze
- **Driver Brand:** Siemens/Kollmorgan/Lenze
- **Up/Down Movement:** Pneumatic